

Hybrid Boiler Systems – The Transition Towards Net Zero.

**Company Details: Combustion Engineering
Association**

Date: 13/05/2026

Leigh Bryan, Manager - Fulton Boilers (GB) Ltd



Improving life through heat transfer solutions

Learning Objectives

- Fundamental differences between electric boilers, fuel fired boilers and heat pumps (hot water and steam systems)
- Real world obstacles to net zero transition and how to overcome them
- De-steaming, system integration and future proofing your infrastructure
- Hydrogen and off grid considerations
- Why a phased approach is the most realistic path forward

Where are we and where do we want to get to?

- An ageing heat transfer infrastructure, still heavily reliant on fossil fuels.
- Buildings and infrastructures not suited to sustainable products.
- Heavily driven through legislation and guidance to reduce emissions.
- High energy prices, restricting single solution options.



- Environmental and financial sustainability.
- Life cycle resilience – operating and maintenance considerations as well as fuel and power changes.
- Realizing each individual project will hold different challenges reflected in each Hybrid solution.

Engineering a Sustainable Future

- Hybrid should systems help solve the challenges of decarbonization:
 - Lowering carbon emissions
 - Reducing up-front costs
 - Reducing operating costs
 - Maintaining setpoints
 - Simplifying the heating plan



Electric Boilers - Characteristics

- Simplistic Pressure Vessel (PV) design reduced thermal stresses.
- Quick start up from cold for electric steam boilers.
- No directly heated PV surfaces
- Tubeless - No “Non-Destructive Testing” (NDT) requirements (SBG01 5 Yearly Ultra sonic for steam and MTHW applications), and reduced footprint required for repair.
- Reduced requirement for water treatment – many smaller electric steam boilers operate without chemical dosing and only a water softener.
 - In the event of scale build up, it will not settle on a directly heated PV surface, greatly reducing the likelihood of a PV failure.
- Reduced operating scope: BG01 not applicable (fuel fired only).

Electric Boilers - Characteristics

- High water content volumes – able to adapt to swing loads on steam.
- No pre purge or post purge burner times to consider – heat source applied instantaneously.
- Reduced installation costs – no flue or fuel supply pipework to consider.
- Reduced pipe work losses – can easily be sited adjacent to or near equipment requiring steam or hot water.
- No arrangement levels or requirement for high integrity water level and TDS controls (BG13/Site specific risk assessment for steam applications)
- Less moving parts compared to a fuel fired boiler – cheaper plus less wear and tear on components.
- Unlike fuel fired, Hot Water applications have no dew point considerations when operating at low water temperatures or high turn down applications.

Electric Boilers - Characteristics

High Efficiency – All the incoming electrical energy is converted into heat energy giving almost 100% Gross efficiency, 97.5%-99% dependant on radiated losses.

Zero Carbon Emissions – Meets Scope 1 as there are no flue gas emissions to consider (note no NOx emissions either).

(**Scope 1 Emissions**— This covers the Green House Gas (GHG) emissions that a company makes directly — for example while running its boilers and fleet vehicles).

Clients can meet **Scope 2** by purchasing Green Energy or producing their own electrical energy to supply the boilers.

Typical Building Energy Profile

- HVAC accounts for the majority of energy use in a commercial building, and a majority of the direct (scope 1) emissions.
- All other consumers of energy in the build are usually either already decarbonized or account for minimal scope 1 emissions.
- For building incorporating steam for process/manufacture the associated energy consumption for the facility will usually be significantly higher than HVAC only.

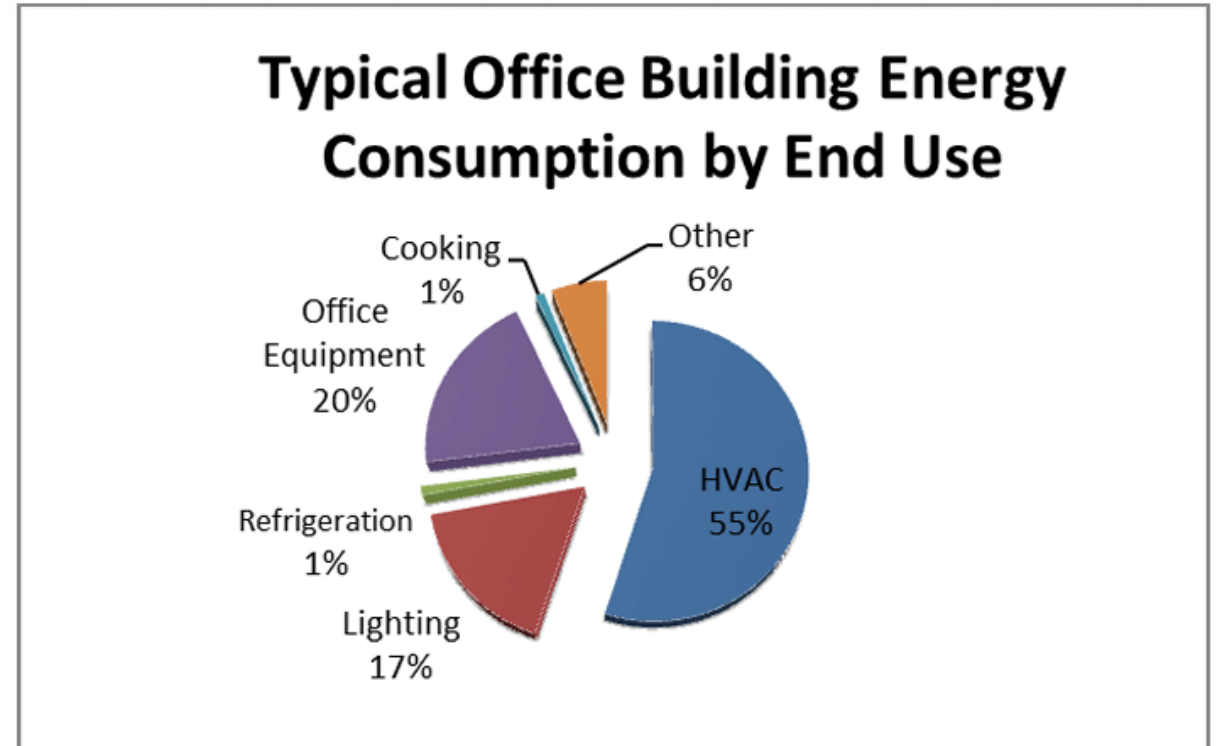

Electric Boiler Restrictions

- Limited Output due to large electrical power (high current at standard voltages) requirements.
- Expensive to run: Electricity Price v Gas or Oil Price

	2019	2020	2021	2022	2024
Nat Gas Cost (Pence/Kwh)	0.68	2.73	5.12	9.55	4.1
Electricity Cost (Pence/Kwh)	26.22	28.6	28.4	28.4	15
Heating Oil Cost (Pence/Kwh)	4.01	4.73	5.3	10.4	N/A

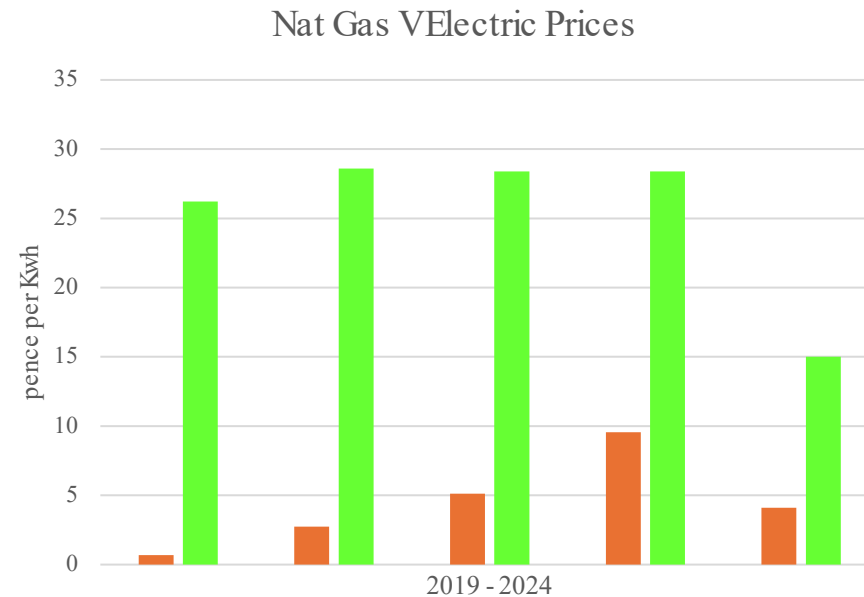

Electric Boiler Running Costs

Self generation on site can significantly impact the gas/electric price gap with competitive options available typically including:

- Solar as a service (no capital outlay)
- Lease and Lease with option to purchase
- Purchase as capital equipment – Payback < 3 years dependant of consumption profile

Equivalent Fixed Electricity Price For 25 Years > 4 Pence Per KWH, dependant on option and site conditions.

The price gap narrows further when the efficiency of gas v electric boilers is included, as well as Scope 2 compliance.

However, cost of energy storage, (battery systems) to ensure power is available when needed and not just when generated, can be prohibitive to the capital investment or lease price.

Steam Boiler Hybrid Systems



Employing an N+1 Strategy for operating redundancy

Example of a variable load, employing more than one boiler to achieve the required output, where the base load or additional load can be met by the electric boiler dependant on priority for either lower carbon emissions as we approach 2030, lower running costs utilising off peak tariffs or energy bundles and/or self generation.

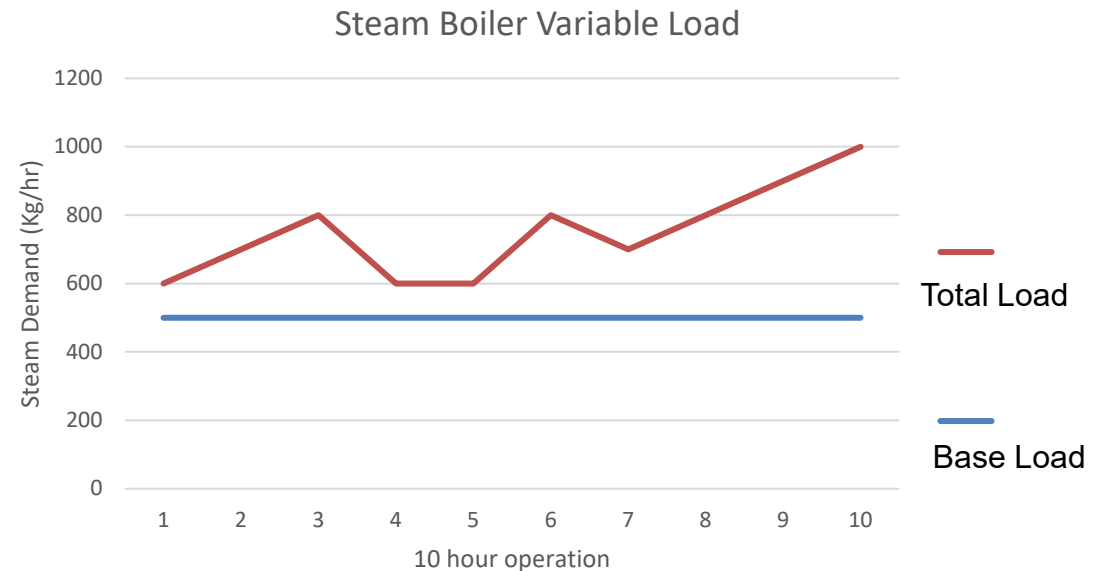

Further Considerations

Fuel considerations

- Future proofing fuel fired boilers against fuel supply changes – hydrogen blend or hydrogen ready products.
- Off grid solutions – where the transportation of Hydrogen isn't financially viable, Bio-LPG or RDME options need to be considered.
- Electrical infrastructure available to support zero Carbon options.
- Plant room space available.
- Steam heat pumps – limited availability, expensive capital outlay.

Hybrid Steam Boilers

Even with tubeless technology, reducing the footprint by 75% against standard boiler designs, the VSRT when incorporated with electric boilers, totalling the same output, will actually have a foot-print approx. only 25% less than a standard dual fuel horizontal fired boiler.

The solution is a single hybrid boiler, the VS RTE, delivering the same steam output, reducing the footprint back to that of a single vertical boiler, but capable of firing gas, electric or co-firing on both to maximize available reduced-price electricity, impact carbon emissions and provide full redundancy against each firing option being available



Further Considerations

Process heating, is steam required?

- Reduced maintenance costs LTHW boilers have no NDTs or annual inspections.
- Sealed system – greatly reducing chemical dosing requirement.
- No regular boiler training required, i.e. City and Guilds or BOAS for managers and operators.
- Less onerous guidance and regulations (BG01/BG13/INDG436).
- Hot water requires less operational interaction – no daily/weekly checks.
- Example: replacing a standard fire tube steam boiler with 3 off 300kw electric boilers actually provided savings over the 15year life cycle including cap-ex.

Challenges to HVAC Decarbonisation

- Capital equipment costs
- Installation & maintenance costs
- Infrastructure upgrade requirements
- Electrical service available
- Space constraints
- Climate
 - Design day temperatures
 - Humidity
- Application
 - Retrofit vs new construction



Hybrid System Benefits

- **Better Efficiency**
 - Intelligently switch between different technologies to maximize overall plant efficiency
- **Lower Costs**
 - Substantially reduce up front installation and equipment cost– Minimize expensive infrastructure upgrades related to high amp draws
- **Decarbonization**
 - Base load with zero emissions equipment, only firing on fossil fuels during peak demand days



Condensing Boiler (Endura XE) Benefits

- Lowest installed cost per kW/hr
- Lowest operating cost per kW/hr
- High setpoints (85°C or higher)
- Compact footprint
 - Substantial m² cost savings
 - Can be mounted indoors, or outdoors in certain climate zones
- Long lasting
 - Will last several decades with routine maintenance

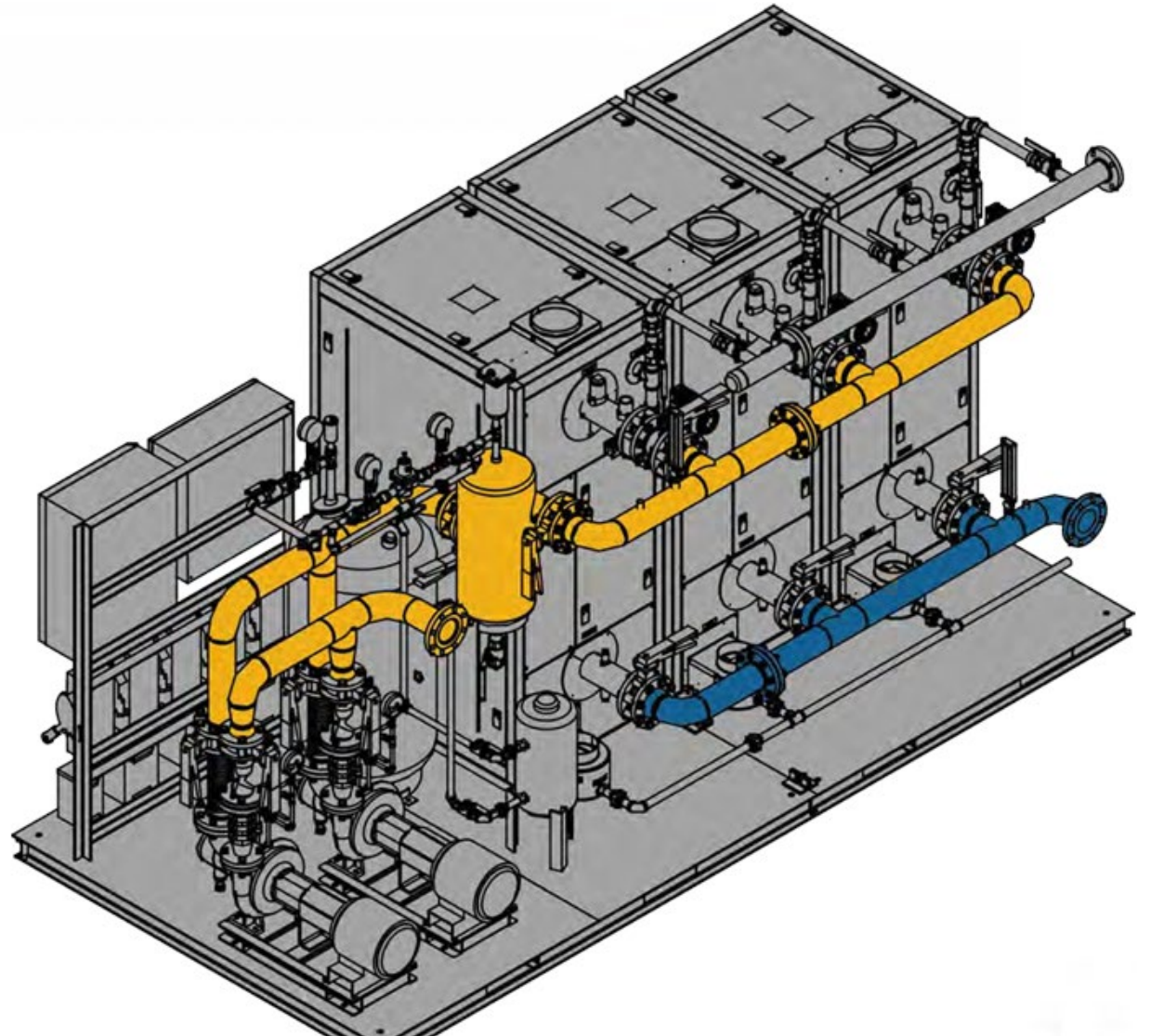

Condensing Boiler Emissions Reduction

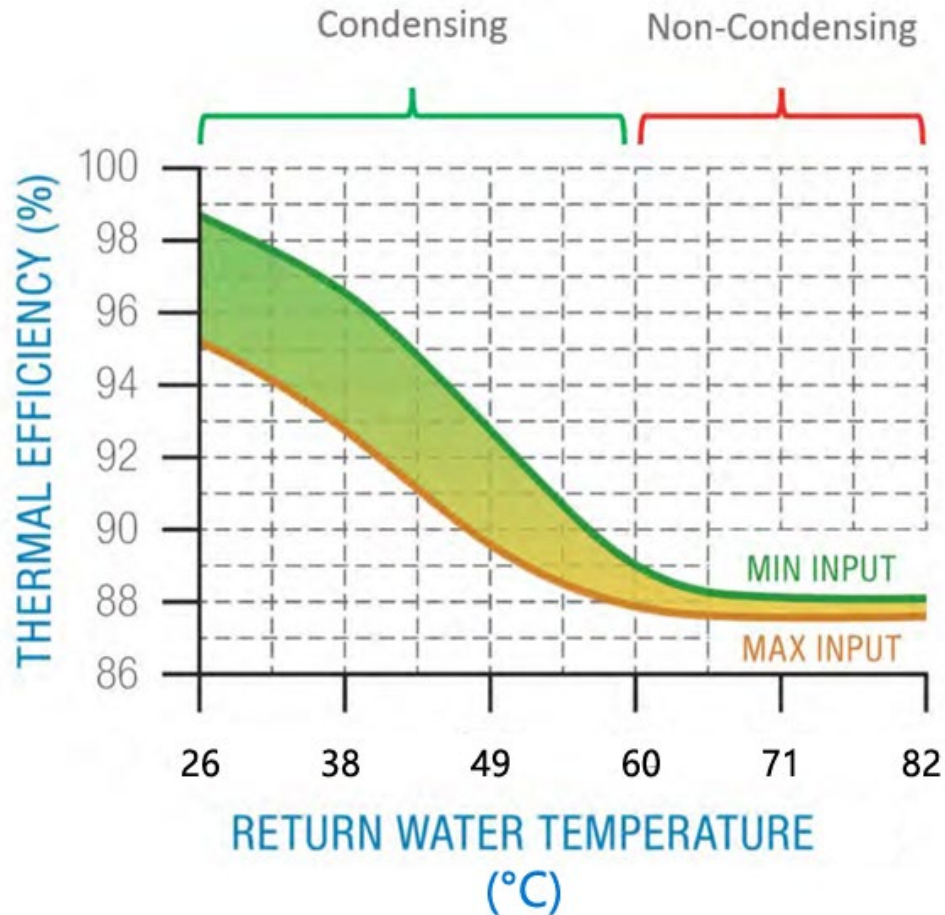

- Modern controls reduce carbon emissions by lowering return water temperatures while still providing reliable heat, efficiencies >88% and up to 99% are achieved.
- Condensing boilers with upgraded combustion controls that include oxygen trim capabilities, continuously tune the air/gas ratio further lowering CO2 emissions.
- Cumulative carbon reduction of up to 29% for new equipment and 40% for retrofits.
- However, there are still associated Scope 1 emissions.

Air Source Heat Pumps

- Uses the refrigeration cycle to move heat from a source (outside air) to a sink (hydronic system)
- Efficiency is measured based on Coefficient of Performance (COP)
 - A COP of 1 is equivalent to 100% thermal efficiency compared to a gas fired boiler
- Other heat pump technologies are available if the heat source is present
 - Water to water
 - Geothermal



Air Source Heat Pump Benefits



- Ultra-high efficiencies
 - COPs as high as 4 or 5 can be achieved under the right operating conditions
- **Zero scope 1 emissions**
- Installed outdoors, saving heating plant room space
- No refrigerants in occupied spaces
- Hydronics are safe, proven, reliable and technology neutral for future-proofing

Air Source Heat Pump Drawbacks

- Larger overall footprint compared to fuel fired and resistive electric boilers
 - No indoor installation option
- Higher upfront costs
- Performance is outdoor temp dependent
 - ASHPs operate at their lowest outputs on cold days, and eventually must be disabled
- Difficult to hit high setpoints ($>57^{\circ}\text{C}$)
 - Retrofits affected more than new construction
- Under certain outdoor conditions, defrost cycles steal heat from the system



Electric Hot Water Boilers (Endura ZE)

- Uses electrical resistance elements to heat the water in lieu of traditional hydrocarbon fuels.
- Can satisfy water temperature requirements (85°C or higher) that most heat pumps cannot.
- Simplified installation
 - No fuel gas piping
 - No flue gas venting
 - No combustion air requirements
 - No condensate removal or pH neutralization
- **Zero scope 1 emissions**



Electric Hot Water Boiler Benefits



- Highly efficient & incredibly reliable
 - Operates at 99% thermal efficiency at all times, irrespective of air temperature, water temperatures, output rate, or system conditions
 - Only efficiency losses are through jacket losses
- Excellent load matching & superior redundancy
 - No pre or post purge required
 - Staging, rotation and backup using individual elements
 - Near infinite turndowns with SCR technology
- Low water side pressure drops
 - Pressure vessels are tanks of water with submerged heating elements

Electric Hot Water Boiler Drawbacks

- Highest energy cost of operation across all options
 - Currently, electricity is more expensive than gas per equivalent unit energy
 - On average in UK electric boilers cost approximately 4 times plus more to operate than an equivalent sized condensing boiler
- Customer may not have electrical service available, and the utility provider might not have a reasonable and timely path to upgrade their infrastructure
- Cable installation cost can be significant for extensive heat outputs



Summary of Hybrid Boiler and Heat Pump System

BUFFER TANK

Additional water volume acts as a thermal flywheel to stabilize heat pump operation, even during defrost.

AIR SOURCE HEAT PUMPS

Carries the base load and operates at high COP during the shoulder seasons.

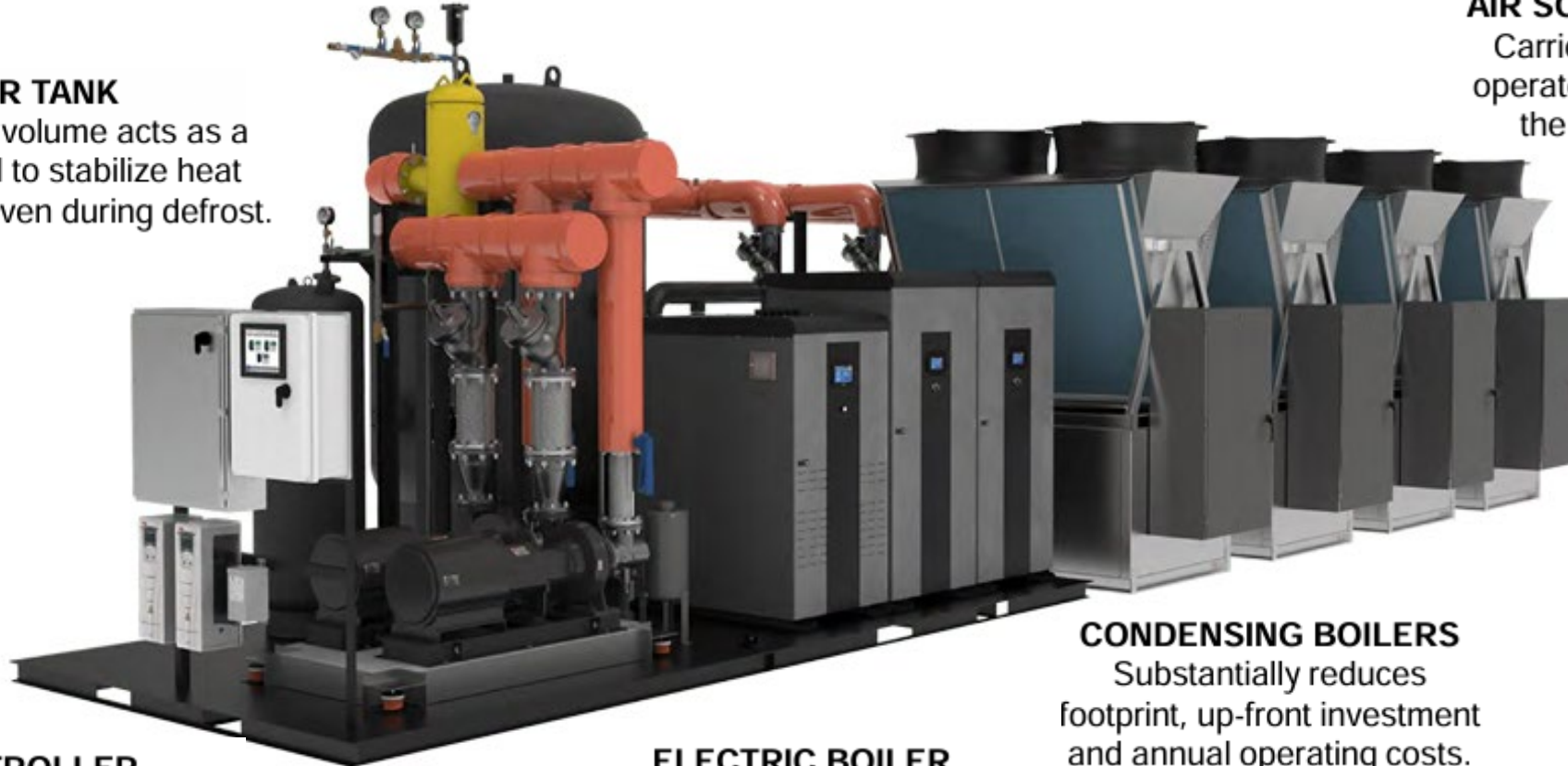

PLANT CONTROLLER

Optimized to sequence modular heating plants to reduce energy use and extend equipment life

ELECTRIC BOILER

Reliable, cost effective, and compact boiler solution with high turndown; satisfies setpoints up to 85°C

CONDENSING BOILERS

Substantially reduces footprint, up-front investment and annual operating costs.

What the Future Holds

Fulton group globally recognise the need to drive Carbon emissions towards Net zero, without negating reductions in NOx emissions, with the UK road map including:

- VSRT-E Hybrid Gas/Fired and Electric steam boilers (co-iring capabilities)
- Extended VSRT range, Nat Gas/LPG only range, to include 100hp and 125hp models, proven gas usage reductions as well as ultra low NOx emissions
- All VSRT/VS RTE models Hydrogen blend (up to 23% mix) tested, with RDME in development
- Electric Endura ZE and Condensing Gas fired Endura XE, LTHW models, to allow integration of hybrid boiler systems alongside heat pumps for a comprehensive hybrid solution



Learning Objectives Review

Has the presentation outlined:

- Fundamental differences between electric boilers, fuel fired boilers and heat pumps (hot water and steam systems)
- Real world obstacles to net zero transition and how to overcome them
- De-steaming, system integration and future proofing your infrastructure
- Hydrogen and off grid considerations
- Why a phased approach is the most realistic path forward

Thank you